

TENSIONED CONTOUR® ELECTROL®

Wall or Ceiling Mounted Electric Projection Screen

When ordering, make appropriate selections:

1. Select size from charts at the lower right.

2. Select viewing surface:

- Da-Mat®
- High Contrast Da-Mat®
- Cinema Vision®
- High Contrast Cinema Vision®
- Pearlescent®
- Audio Vision®
- High Contrast Audio Vision®
- High Contrast Cinema Perf®
- Da-TeX® (Rear)
- Dual Vision®
- GREENGUARD® and GREENGUARD® Children and Schools Certified.

3. Options:

- Single Motor Low Voltage Control (LVC) external.
- Single Motor Low Voltage Control (LVC) built-in.
- Wireless Remote Control for LVC.
 - Radio Frequency Remote.
 - Radio Frequency Range Extender available
 - Infrared Remote.
- Key Locking Cover Plate for 120V or LVC Switch.
- Silent Motor for sizes up to 9'x12'.
- Silent Motor with Integrated LVC for sizes up to 9'x12'.
- Key Operated Switch for 120V only (NOTE: Cannot be used with LVC).
- 220 Volt (50 Hz) Motor.
- Video Projector Interface Control - external.
- Video Projector Interface Control - built-in (adds 3¼" to length of case).
- SCB-100 RS-232 Serial Control Board - external.
 - NET-100 Ethernet-Serial Adapter
- SCB-100 RS-232 Serial Control Board - built-in (adds 3¼" to length of case).
 - NET-100 Ethernet-Serial Adapter
- SCB-200 RS-232 Serial Control Board - built-in (adds 3¼" to length of case).
 - NET-200 Ethernet-Serial Adapter
- WC-200 Wall Controller
- IR-200 Infrared Remote
- Veneer Case Cover (Choose from seven standard veneers).
 - Light Oak
 - Medium Oak
 - Natural Walnut
 - Heritage Walnut
 - Mahogany
 - Cherry
 - Honey Maple
- Graphite case color.
- White case (black standard).



- Stylish, curved aluminum extruded case.
- Optional low voltage control can be built-in the case.
- Two piece case allows easy access to motor and roller.
- Tab guide cable system holds screen surface flat.

SUGGESTED SPECIFICATIONS:

_____ projection screen(s), _____ (H) x _____ (W), electrically operated 120 volt (60 Hz) not more than 2.4 amp. Shall have specially designed motor mounted inside the roller, to be three wire with ground, quick reversal type, oiled for life, with automatic thermal overload cutout, integral gears, capacitor and an electric brake to prevent coasting. To have preset but adjustable limit switches to automatically stop the picture surface in the "up" and "down" positions. Junction box shall be integrated into the housing making it possible to install the housing and wire to the building's electrical system during construction. The junction box shall contain a quick connect connector that is mounted in the housing for easy plug-in connection to the motorized fabric and roller assembly. The motorized fabric and roller assembly may be installed in the case at the factory or at a later time at the job site. The roller to be of rigid metal. Roller mounting brackets to be adjustable to allow centering or offsetting of the screen within the case. Screen case to be a two piece design made of extruded aluminum. Case to be finished in black, lightly textured powder coat. Screen fabric to be flame retardant and mildew resistant vinyl with black masking borders standard. Each side of fabric to have a tab guide cable system to maintain even lateral tension and hold surface flat. Bottom of fabric to be inserted into a custom aluminum slat bar with added weight to provide vertical tension on the screen surface. The ends of the slat to be protected by heavy duty plastic caps enclosing a preset adjustable mechanism for screen tensioning. Screen to include a three-position control switch and cover plate. Screen to be listed by Underwriters' Laboratories.



All viewing surfaces will be seamless.
 All viewing surfaces are standard with black backing except Da-TeX® and Dual Vision.
 Audio Vision, High Contrast Audio Vision and High Contrast Cinema Perf available in sizes up to 87" x 116" in Video Format and 78" x 139" in HDTV Format.

Detailed dimensional drawings, wiring diagrams and installation instructions available upon request.

Specifications subject to change without notice.

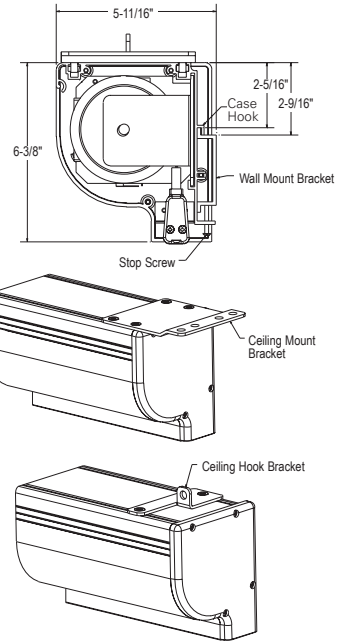

4:3 VIDEO FORMAT

Viewing Area H x W	Nominal Diagonal	Overall Case Length	Approx. Shipping Wt. Lbs.
43" x 57"	72"	77¼"	66
50" x 67"	84"	87¾"	73
60" x 80"	100"	102¼"	84
69" x 92"	120"	111¾"	94
87" x 116"	150"	137¼"	114
108" x 144"	180"	167¾"	135
120" x 160"	200"	184¼"	148

16:9 HDTV FORMAT

Viewing Area H x W	Nominal Diagonal	Overall Case Length	Approx. Shipping Wt. Lbs.
45" x 80"	92"	100¼"	79
52" x 92"	106"	113¼"	83
54" x 96"	110"	117¼"	86
58" x 104"	119"	125¾"	95
65" x 116"	133"	138¾"	114
78" x 139"	159"	159¾"	134
90" x 160"	184"	181¾"	148

SQUARE FORMAT

Viewing Area H x W	Overall Case Length	Approx. Shipping Wt. Lbs.
50" x 50"	70¾"	61
60" x 60"	82¼"	69
70" x 70"	93¾"	77
84" x 84"	105¼"	88
6' x 8'	115¾"	97
8' x 8'	118¼"	100
7' x 9'	129¼"	108
9' x 9'	131¾"	105
8' x 10'	142¼"	118
10' x 10'	145¼"	120
9' x 12'	167¾"	130
12' x 12'	171¾"	135

Overall case length dimensions ±¼".

Note: Add 3¼" to overall case length for built-in SCB-100 or SCB-200.

Note: Custom formats and sizes available upon request.

Note: All sizes come standard with 12" black drop at top.