

# Plasma Wall Mount Articulating Arm PWM-AR1

## Form E-446

### Caution!

This unit is designed for wall installation. Qualified personnel using the appropriate fasteners should mount this unit. The surface to which this unit is mounted must be capable of supporting a static load of four times the combined weight of the plasma unit and mount. Do not attach to plaster, drywall, or paneling alone.

### Tools Required

7/16" wrench

### Procedure

Use the chart below to select the proper fastener kit for your specific wall application. Determine the location of the mounting hardware and follow the directions for installation.

Wall construction	Fastener Kit Part #	Hole size
Concrete	A101 (3/8" cap screws & hollow set drop in anchors)	5/8"
Wood stud	A105 (3/8" lag screws)	3/16"
Metal stud or Concrete block	A109 (3/8" cap screws & togglers)	3/4"

### INSTALLATION

1. Remove contents from carton and examine.
2. Mount the Wall Plate to the wall. See Figure 1.
3. Attach the Arm Assemblies to the plate as shown.
4. Attach the Zee-Bar Plate Assembly to the arms utilizing four plastic washers.
5. Attach Zee-Bars to the Zee-Bar Plate Assembly.
6. Attach the Zee-Bar Extensions (if needed) by utilizing slots and holes nearest the end of the Zee-Bar.

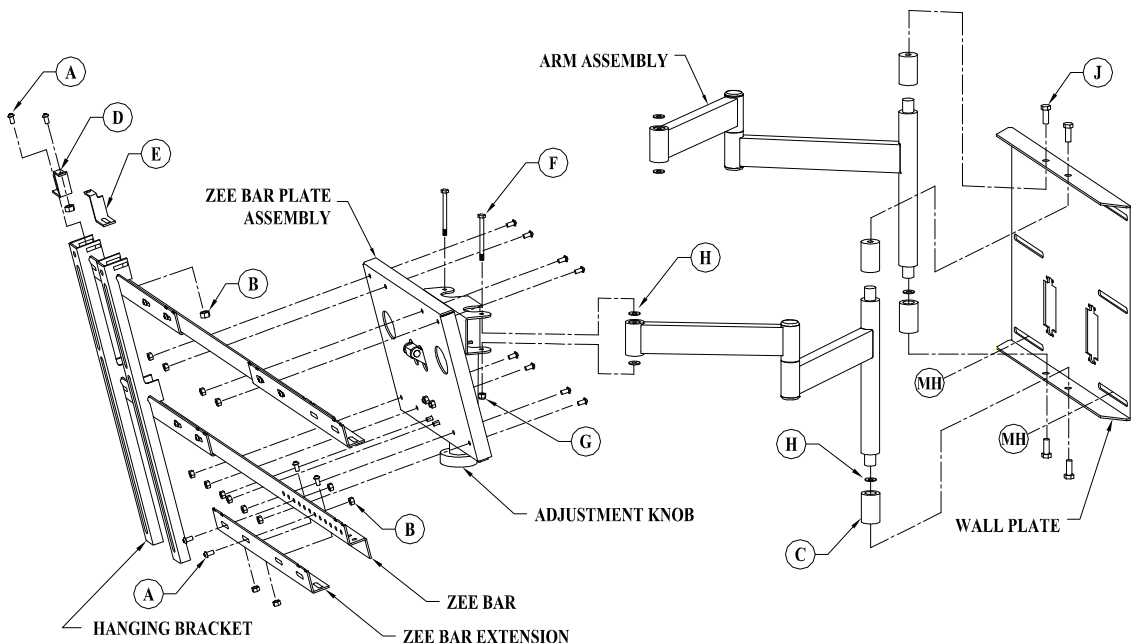

Figure 1

### PLASMA UNIT INSTALLATION

1. Mount the Hanging Brackets to the back of the Plasma unit utilizing all the fastener points recommended by the plasma manufacture. See Figure 2.

**Note:** It is the responsibility of the installer to obtain any additional fasteners needed to secure the hanging brackets to the plasma unit.

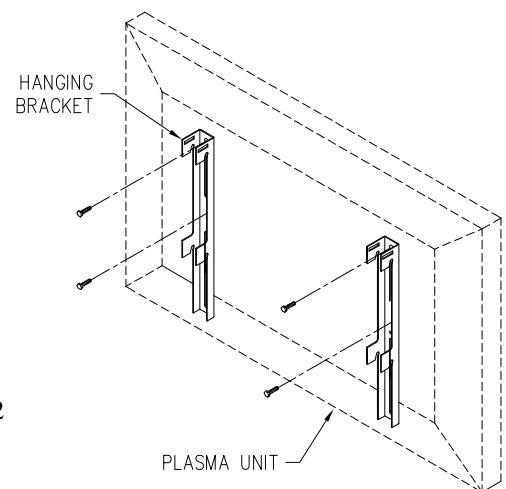

Figure 2

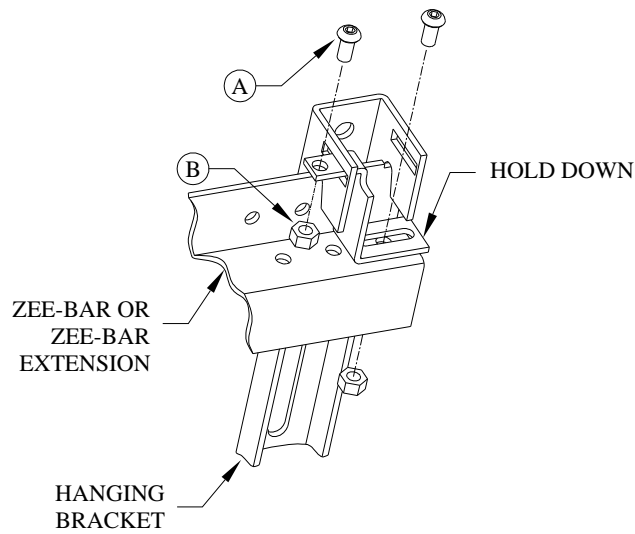

Figure 3

2. Hang the plasma unit on the wall mount making sure the top and bottom notches on each Hanging Bracket are placed over the upper and lower Zee Bars.
3. Attach the Hold-Downs. See Figure 3.
4. Tilt the unit by using the Adjustment Knob. See Figure 1.

**HARDWARE CHART**

	<b>Qty</b>	<b>Description</b>
A	28	Screw, BHSCS, 1/4"-20 x 1/2"
B	28	Nut, Hex, 1/4"-20
C	4	Bearing
D	1	Bracket, LH, Hold down
E	1	Bracket, RH, Hold down
F	2	Screw, HHCS, 1/4"-20 x 3"
G	2	Nut, Lock, 1/4"-20 Nylon
H	6	Washer, flat, 1/4", Plastic
J	4	Screw, HHCS 3/8"-16 x 1"
MH	6	Mounting Hardware

\*MH- To be provided by installer

**DA-LITE SCREEN COMPANY, INC.**

3100 North Detroit Street  
 Post Office Box 137  
 phone: 574/267-8101  
 800-622-3737  
<http://www.da-lite.com>  
 e-mail: info@da-lite.com